

# BF

2-φX鑽穿のY鑽深Z  
2-X drill ØY counter bore depth Z

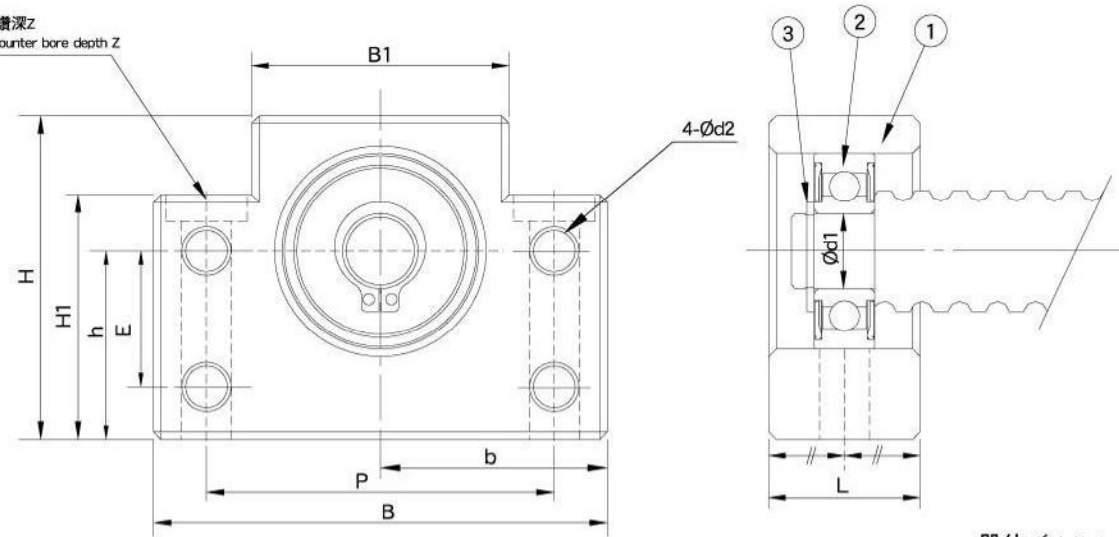

單位/Unit : mm

型號 Model No.	軸徑 Shaft diameter d1	L	B	H	b ±0.02	h ±0.02	B1	H1	E	P	d2	X	Y	Z	使用軸承 Bearing	使用C型扣環 Snap ring	重量 Weight (Kgs)
BF10	8	20	60	39	30	22	34	32.5	15	46	5.5	6.6	10.8	5	608ZZ	S 08	0.3
BF12	10	20	60	43	30	25	34	32.5	18	46	5.5	6.6	10.8	1.5	6000ZZ	S 10	0.3
BF15	15	20	70	48	35	28	40	38	18	54	5.5	6.6	11	6.5	6002ZZ	S 15	0.4
BF17	17	23	86	64	43	39	50	55	28	68	6.6	9	14	8.5	6203ZZ	S 17	0.75
BF20	20	26	88	60	44	34	52	50	22	70	6.6	9	14	8.5	6004ZZ	S 20	0.76
BF20H	20	26	88	74	44	48	52	64	-	70	-	9	14	8.5	6004ZZ	S20	1.02
BF25	25	30	106	80	53	48	64	70	33	85	9	11	17	11	6205ZZ	S 25	1.43
SF25	25	32	128	89	64	51	76	78	-	102	-	14	20	13	6205ZZ	S 25	-
BF30	30	32	128	89	64	51	76	78	33	102	11	14	20	13	6206ZZ	S 30	1.94
BF35	35	32	140	96	70	52	88	79	35	114	11	14	20	13	6207ZZ	S 35	2.25
SF40	40	32	140	96	70	52	88	79	-	114	-	14	20	13	6208ZZ	S 40	-
BF40	40	37	160	110	80	60	100	90	37	130	14	18	26	17.5	6208ZZ	S 40	3.3